

Illustrated Parts Catalogue



UL520/15
AERO ENGINE

Please fill in your engine and aircraft details for further reference:

Engine Serial No. :

Aircraft type :

Model :

Serial No. :

Registration :

Introduction

Remarks

The illustrations in this Illustrated Parts Catalogue show the typical construction. They may not represent in full detail or the exact shape of the parts which have the same or similar function.

Modifications

All efforts are made to ensure the accuracy of this Illustrated Parts Catalogue at the time of publication. ULPower, however, maintains a policy of continuous improvement of its products without imposing upon itself any obligation to install them on its products previously manufactured.

ULPower reserves the right at any time to discontinue or change specifications, designs, features, models or equipment without incurring obligation.

Engine serial number

On all enquiries or spare parts orders, always indicate the engine serial number, as the manufacturer makes modifications to the engine for further development.

The engine serial number is located at the front left side of the crankcase (above oil filter).

Structure

Each section of this Illustrated Parts Catalogue starts with an exploded view or assembly drawing on the left side. The corresponding heading and the listing of the parts is on the right side and the following pages.

For each assembly drawing the right number of parts is listed in the relevant column. Because an engine can contain multiple times the illustrated assembly or a part can be used in several different applications, the total number of parts per engine is also given.

Generally all fasteners are tightened with a torque wrench. The "Notes" column indicates the appropriate torque or refers to extra information at the end of the section.

Blank

Table of Contents

Introduction	1
Remarks	1
Modifications	1
Engine serial number	1
Structure	1
Table of Contents.....	3
Cylinder Head and Cylinder	5
Crankcase, Oil Sump and Dipstick.....	7
Oil Pump Assembly: SE040515.....	9
Camshaft and Valve Train.....	11
Crankshaft, Conrod and Piston	13
Inlet Manifold, Injectors and Throttle (single ECU).....	15
Inlet Manifold, Injectors and Throttle (double ECU)	19
Fuel lines.....	23
Engine Mount Plate, Starter and Alternator	25
Exhaust System	29
Breather and Oil/Air Separator	31
Oil Thermostat : E042515	33
Ignition and Engine Control Unit	35
Accessories.....	37
Section of drawings	38
Notes	39
Revision.....	40

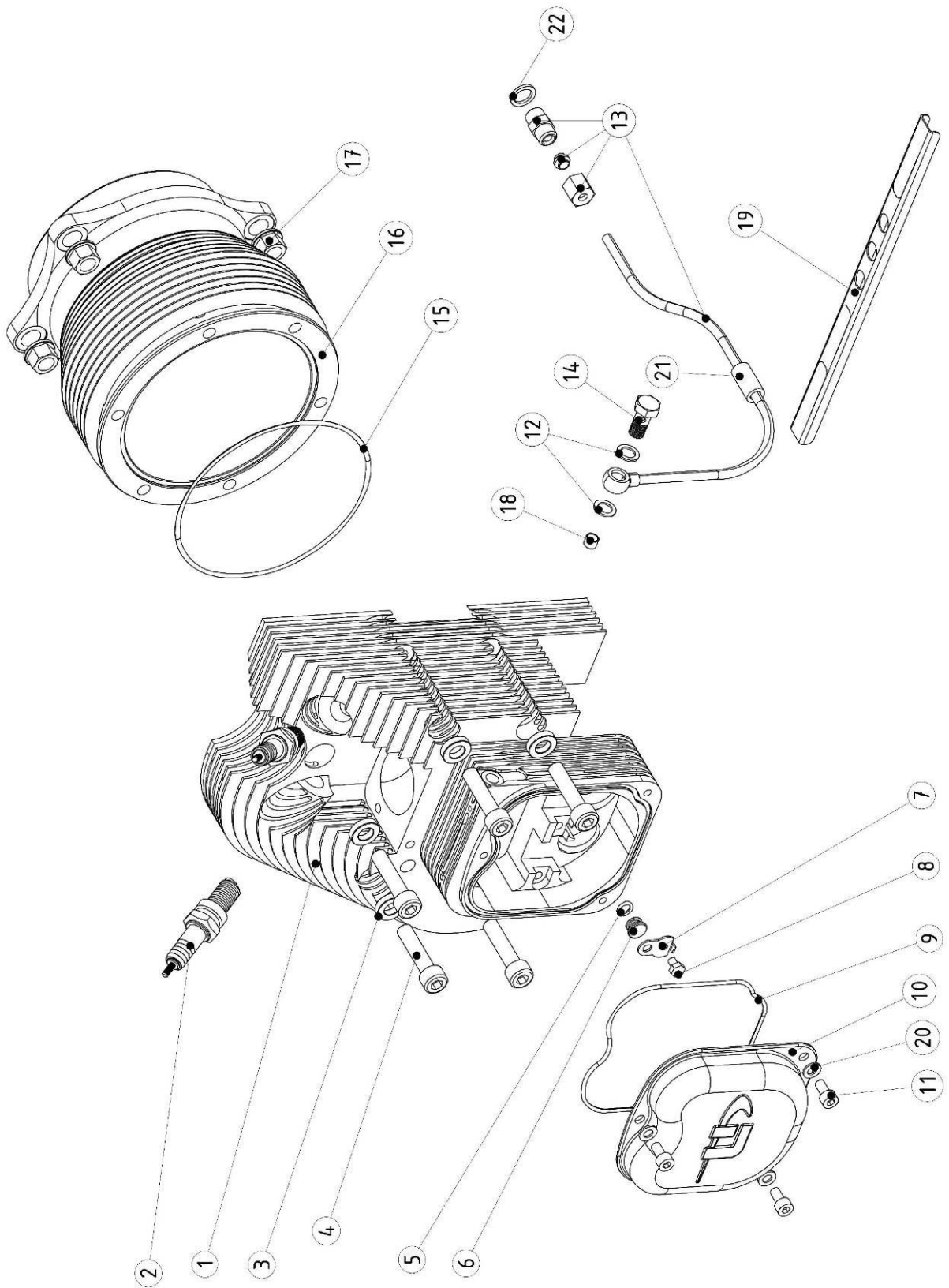

Cylinder Head and Cylinder

Item	Part No.	Description	Parts in assembly	Note
1		Cylinder Head Assembly	1	
	BE012512	Cylinder Head Right	0	
	BE012513	Cylinder Head Left	1	
	SBE012512	Cylinder head middle	0	
	E035001	Valve Guide	2	
	E034501	Exhaust Valve Seat	1	
	E034502	Inlet Valve Seat	1	
2	E070502	Spark Plug	2	21Nm (1)
3	E012504	Cylinder Head Washer	6	
4	F0408035	Socket Cap Screw - M8x1x35 - 12.9 Steel	6	36 Nm (1)
5	S1006015	O-Ring Viton 6x1.5	1	
6	E012505	Cylinder Head Plug	1	
7	E012503	locking plate M4 cyl head	1	
8	F1004006	Hexagon head screw - M4x6 - 8.8 Steel - Zinc Plated	1	1.5 Nm
9	S1100020	O-Ring Viton 99x2	1	
10	E012506	Valve Cover	1	
11	F0105016	Socket Cap Screw - M5x16 - 8.8 Steel - Yellow Passivated	3	6 Nm
12	S3081210	Copper Sealing Ring ø8x12x1	2	
13	BE041505	Cylinder Head Oil Line Left Assembly	1	6Nm
	BE041506	Cylinder Head Oil Line Right Assembly	0	
14	F2520800	Banjo Bolt M8x1	1	8 Nm
15	E013001	Cylinder Gasket	1	(4)
16	SBE012004	Cylinder	1	(5)
17	E011003	Flanged Nut M10x1	4	36 Nm
18	E012511	Cylinder Head Oil Filter	1	
19	SE012530	Bracket oil line	1	
20	F2110050	Nordlock washer	3	
21	F2550013	Cloth braided hose Ø5,5 x Ø10,5	1	
22	S3101415	Copper Ring Ø10x14x15	1	

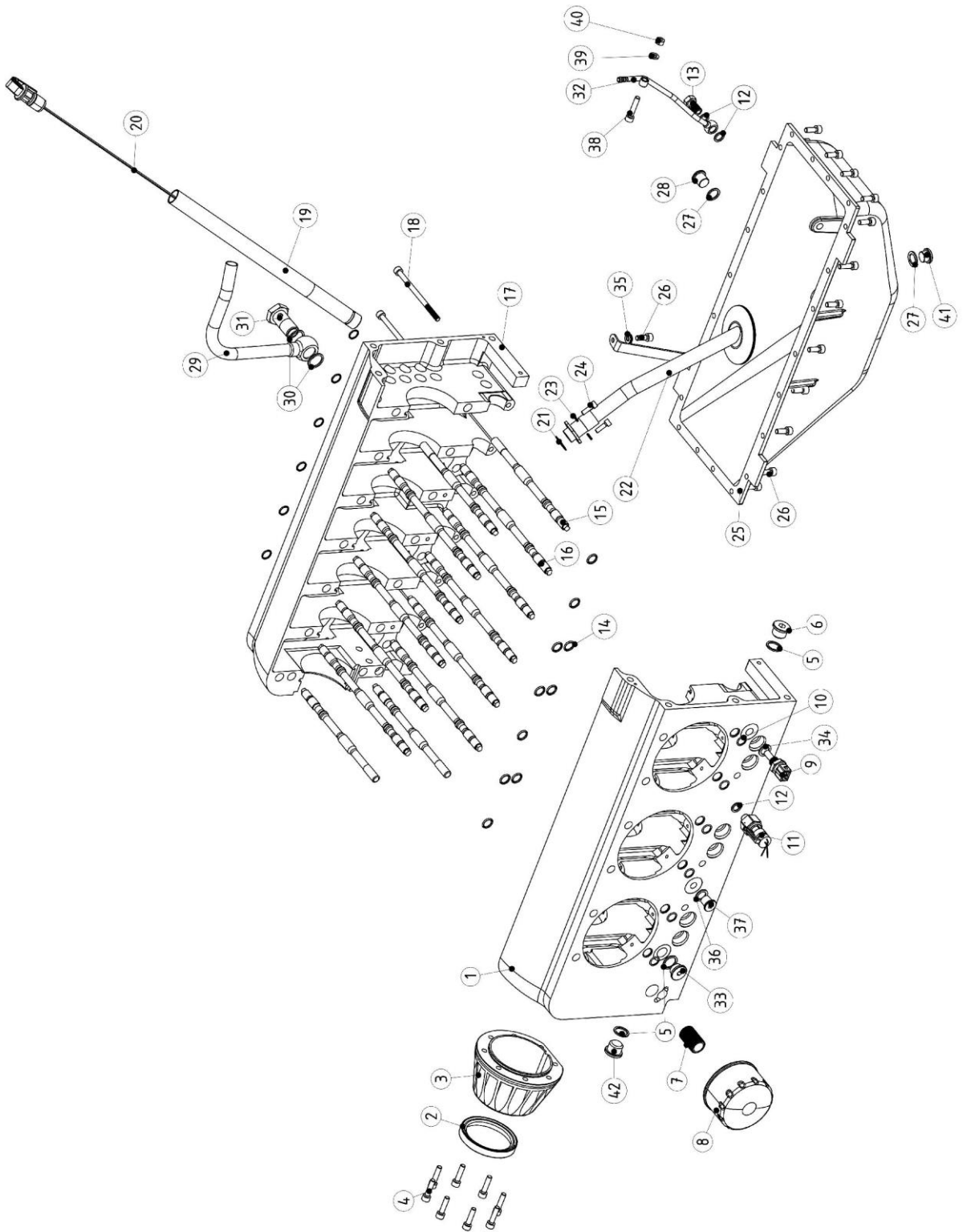

Crankcase, Oil Sump and Dipstick

Item	Part No.	Description	Parts in assembly	Note
1	SE010502	Crankcase Left	1	(7)
2	S2607510	Oil Seal Viton 60x75x10 GR	1	(5)
3	BE010509	Thrust Bearing Mount	1	(7)
4	F0106025	Socket Cap Screw - M6x25 - 8.8 Steel - Yellow Passivated	8	10 Nm
5	S3162015	Copper Sealing Ring \varnothing 16x20x1.5	3	
6	SE041045	Hexagon Socket Screw Plug - M16x1.5/45°	1	25 Nm (2)
7	E042006	Oil Filter Screw M20x1.5	1	/
8	E042010	Oil Filter	1	15 Nm (3)
9	E081516	Oil Temperature Sensor	1	20 Nm
10	S1011015	O-Ring Viton \varnothing 11x1.5	12	
11	E081507	Oil Pressure Sensor	1	
12	S3101415	Copper Sealing Ring \varnothing 10x14x1.5	3	
13	F2521000	Banjo Bolt M10x1 L = 25	1	10 Nm
14	S1012020	O-Ring Viton \varnothing 12x2	10	(3)
15	E011002	Stud Short	4	(1)
16	E011001	Stud Long	10	
17	SE010501	Crankcase Right	1	
18	F0206100	Socket Cap Screw - M6x100 - 8.8 Steel - Zinc Plated	6	10 Nm
19	E043003	Dipstick Tube	1	(6)
20	SE043004	Dipstick	1	
21	S1020010	O-Ring Viton \varnothing 20x1	1	
22	SE044501	Oil Pickup Tube with Filter	1	
23	F2110050	NordLock Washer M5	2	
24	F0105016	Socket Cap Screw - M5x16 - 8.8 Steel - Yellow Passivated	2	6 Nm
25	SE041001	Oil Sump	1	(7)
26	F0106016	Socket Cap Screw - M6x16 - 8.8 Steel - Yellow Passivated	22	10 Nm
27	S3142015	Copper Sealing Ring \varnothing 14x20x1.5	2	
28	E041020	Carter plug Magnet M14x1,5	1	25 Nm
29	SE043510	Oil breather tube	1	
30	S3182415	Copper sealing ring \varnothing 18x24x1.5	2	
31	F2521815	Banjo bolt M18x1.5	1	25 Nm
32	SE043511	Oil return tube sump	1	
33	E041015	Plug 5/8 - 18UNF	1	
34	S3121715	Copper sealing ring d12xD17x1.5	1	
35	F2110060	Nordlock Washer M6	1	
36	S3121715	Copper sealing ring d12xD17x1.5	1	
37	F4621215	Hexagon socket screw plug M12x1.5 (Single ECU)	1	25Nm (2)
	E081518	Oil Pressure sensor (double ECU)	1	12Nm
38	F0206028	Socket Cap Screw M6x28 - 8,8 Zn	1	
39	F2110060	Nordlock Washer M6	1	
40	F5103060	prevailing torque type hex nut - M6 - Zn	1	
41	E041010	Plug M14x1,5	1	
42	F4621615	Hexagon Socket Screw Plug - M16x1,5 Zn	1	25Nm (2)

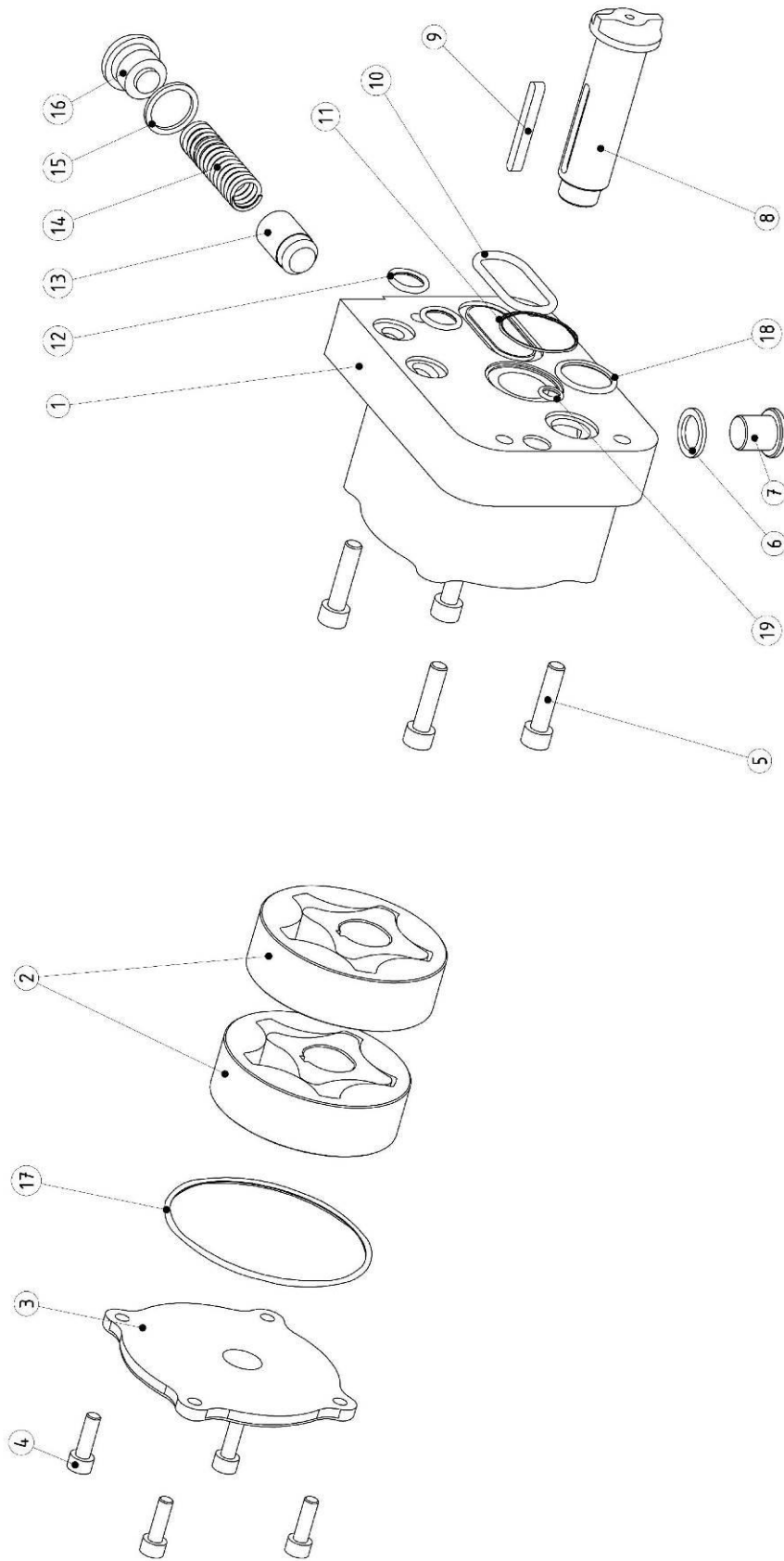

Oil Pump Assembly: SE040515

Item	Part No.	Description	Parts in assembly	Note
1	SE040510	Oil Pump Housing	1	(7)
2	E040512	Oil Pump Rotor Set b = 20	2	
3	E040509	Oil Pump Cover	1	
4	F0105016	Socket Cap Screw - M5x16 - 8.8 Steel - Yellow Passivated	4	6 Nm
5	F0106025	Socket Cap Screw - M6x25 - 8.8 Steel - Yellow Passivated	4	10 Nm
6	S3121715	Copper Sealing Ring $\varnothing 12 \times 17 \times 1.5$	1	
7	F4621215	Hexagon Socket Screw Plug - M12x1.5	1	25 Nm
8	SE040513	Oil Pump Shaft	1	
9	F1704035	Parallel Key 4x4x35	1	
10	S1030020	O-Ring Viton $\varnothing 30 \times 2$	1	
11	S1026010	O-Ring Viton $\varnothing 26 \times 1$	1	
12	S1011020	O-Ring Viton $\varnothing 11 \times 2$	2	
13	BE040516	Plunjer oil pump B20	1	
14	E040506	Pressure Relief Spring	1	
15	S3162015	Copper Sealing Ring $\varnothing 16 \times D20 \times 1.5$	1	
16	E041040	Hexagon Socket Screw Plug - M16x1.5	1	25 Nm
17	S1070020	O-ring Viton 70x2	1	
18	S1016020	O-Ring Viton $\varnothing 16 \times 2$	1	
19	S1006015	O-ring Viton $\varnothing 6 \times 1,5$	1	

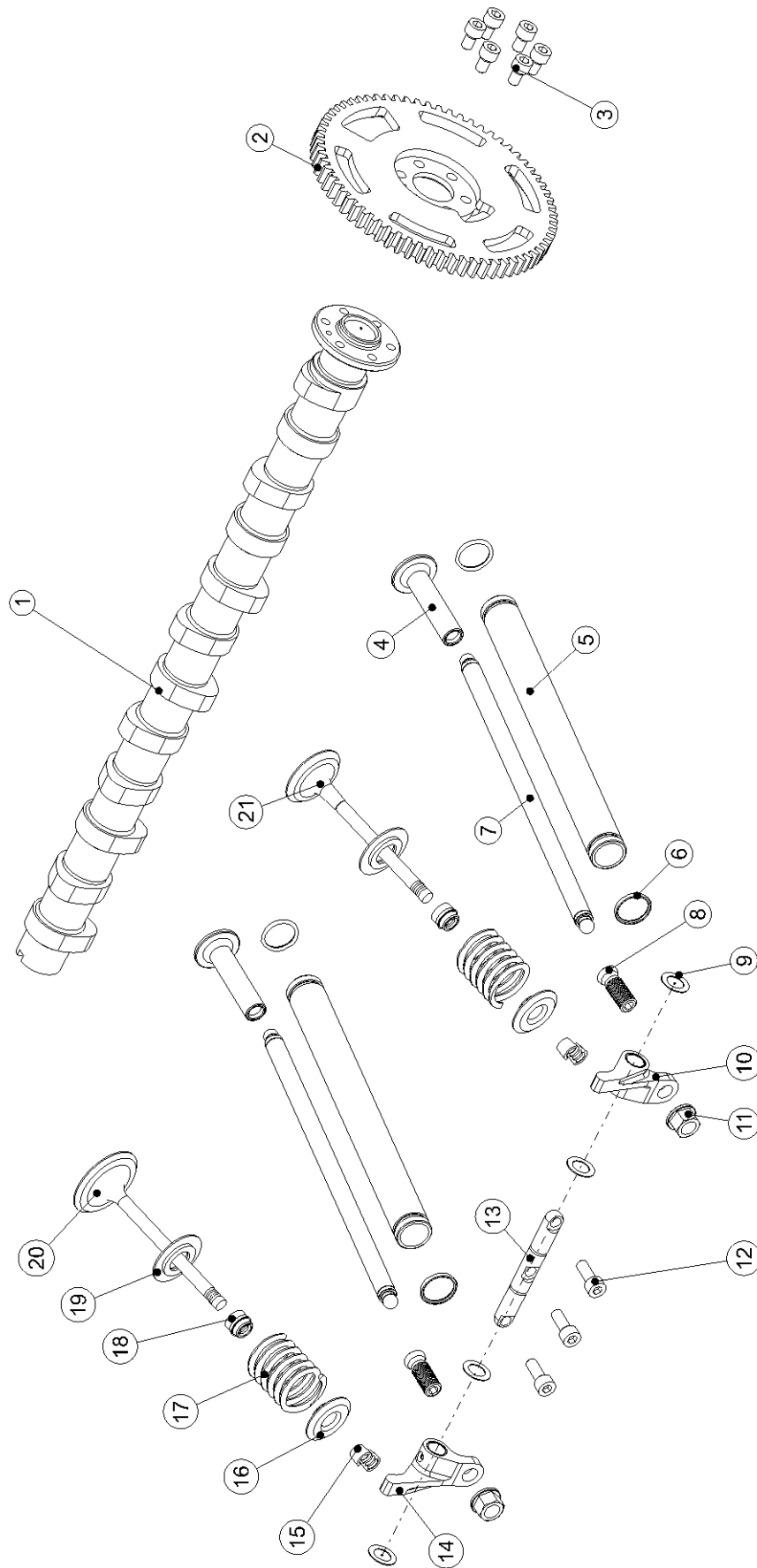

Camshaft and Valve Train

Item	Part No.	Description	Parts in assembly	Note
1	SBE030501	Camshaft 5.2	1	
2	SE031001	Camshaft Gear	1	
3	F0306012	Socket Cap Screw - M6x12 - 12.9 Steel	6	18 Nm (2)
4	E031501	Cam Follower	2	
5	BE041501	Oil Return Tube	2	
6	S1017020	O-Ring Viton \varnothing 17x2	4	(3)
7	BE032005	Push Rod	2	
8	E032505	Tappet Adjusting Screw	2	
9	F2311016	Shim Ring 0.5mm - \varnothing 10x16	4	
10	E032506	Rocker Tappet Right	1	
11	E011003	Flanged Nut M10x1	2	20 Nm
12	F0306016	Socket Cap Screw - M6x16 - 12.9 Steel	3	12 Nm (2)
13	E032504	Rocker Shaft	1	
14	E032507	Rocker Tappet Left	1	
15	E034003	Collet Valve Spring Lock	4	
16	E034002	Valve Spring Retainer Top	2	
17	E033501	Valve Spring	2	
18	E035501	Valve Stem Seal	2	
19	E034001	Valve Spring Retainer Bottom	2	
20	E033002	Inlet Valve	1	
21	E033001	Exhaust Valve	1	

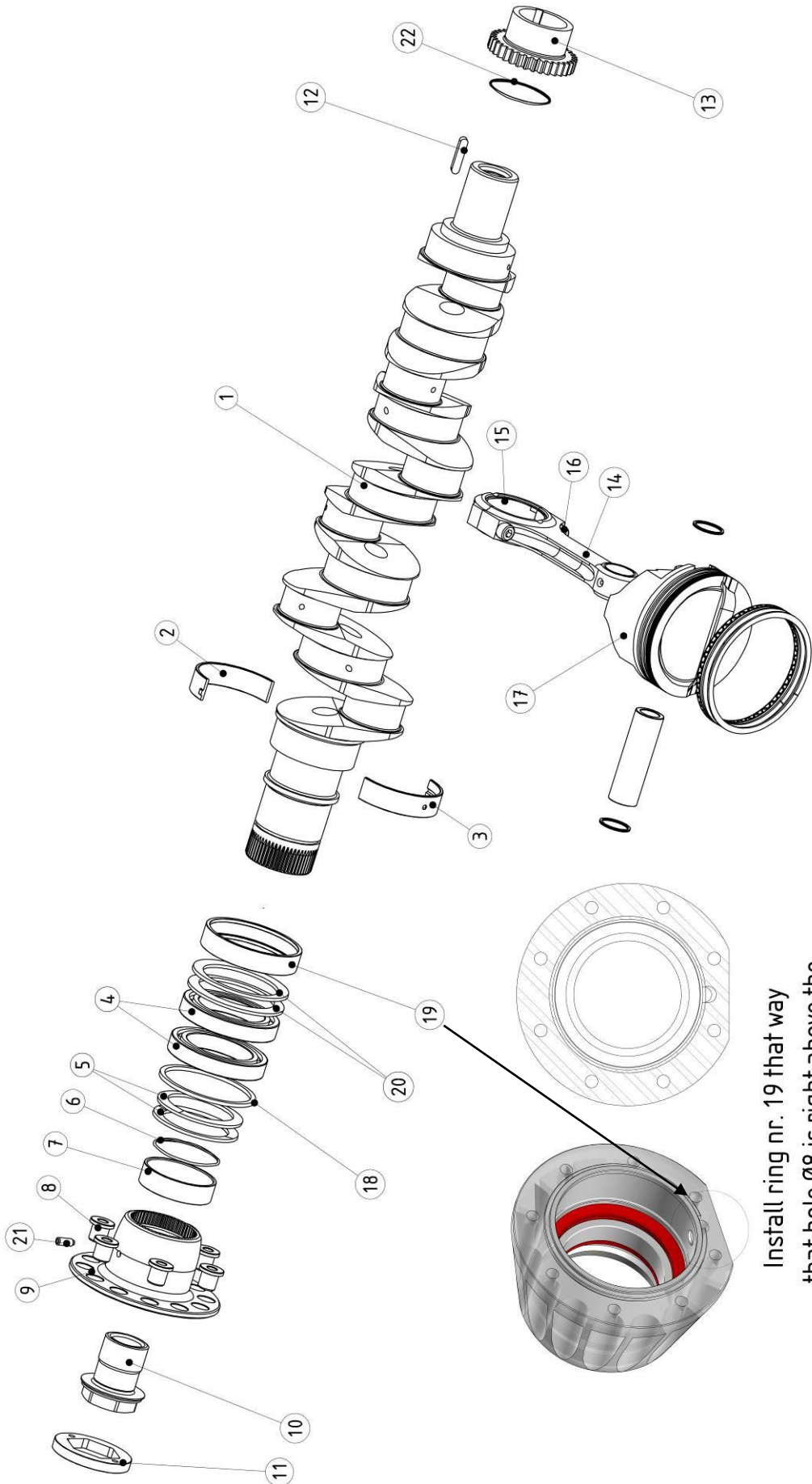

Install ring nr. 19 that way that hole Ø8 is right above the groove in the Thrust Bearing Mount

Crankshaft, Conrod and Piston

Item	Part No.	Description	Parts in assembly	Note
1	SBE020502	Crankshaft	1	
2	BE022005	Crankshaft Bearing Set (contains piece 2, 3)	7	
3		Crankshaft Bearing Half 1		
3		Crankshaft Bearing Half 1		
4	E022001	Thrust Bearing	2	
5	E021502	Thrust Bearing Disc Spring	2	
6	S1052020	O-Ring Viton $\varnothing 50 \times 1.78$	1	
7	E021504	Thrust Bearing Retention Ring	1	
8	E023004	Prop Flange Drive Lug $\varnothing 14$	6	
9	E022501	Propeller Flange L = 55 (Standard)	1	
	E022505	Propeller Flange L = 90 (6)		
	E022506	Propeller Flange L = 35 (6)		
	E022504	Propeller Flange L = 110 (6)		
10	E023001	Prop Flange Bolt	1	300Nm (1)
11	E022510	Locking propellor flange bolt	1	
12	F1706030	Parallel Key 6x6x30	1	
13	E021001	Crankshaft Gear	1	
14	BE023506	Connecting Rod Assembly	6	
15	E022004	Connecting Rod Bearing set (2)	6	
16	F0408035	Socket Cap Screw - M8x1x35 - 12.9 Steel	12	36 Nm (2+4)
17	E024009	Piston -18cc ("I" engines)	6	
	E024008	Piston -7cc ("iS" engines)		
18	E021506	Thrust Bearing Disc	1	
19	SE021515	Thrust Bearing Retention Ring Outer	1	
20	E021510	Thrust Bearing Disc Spring Outer	2	
21	F1306012	hexagon socket set screw M6x12	1	10 Nm
22	S1047017	O-ring Viton 47.34x1.78	1	

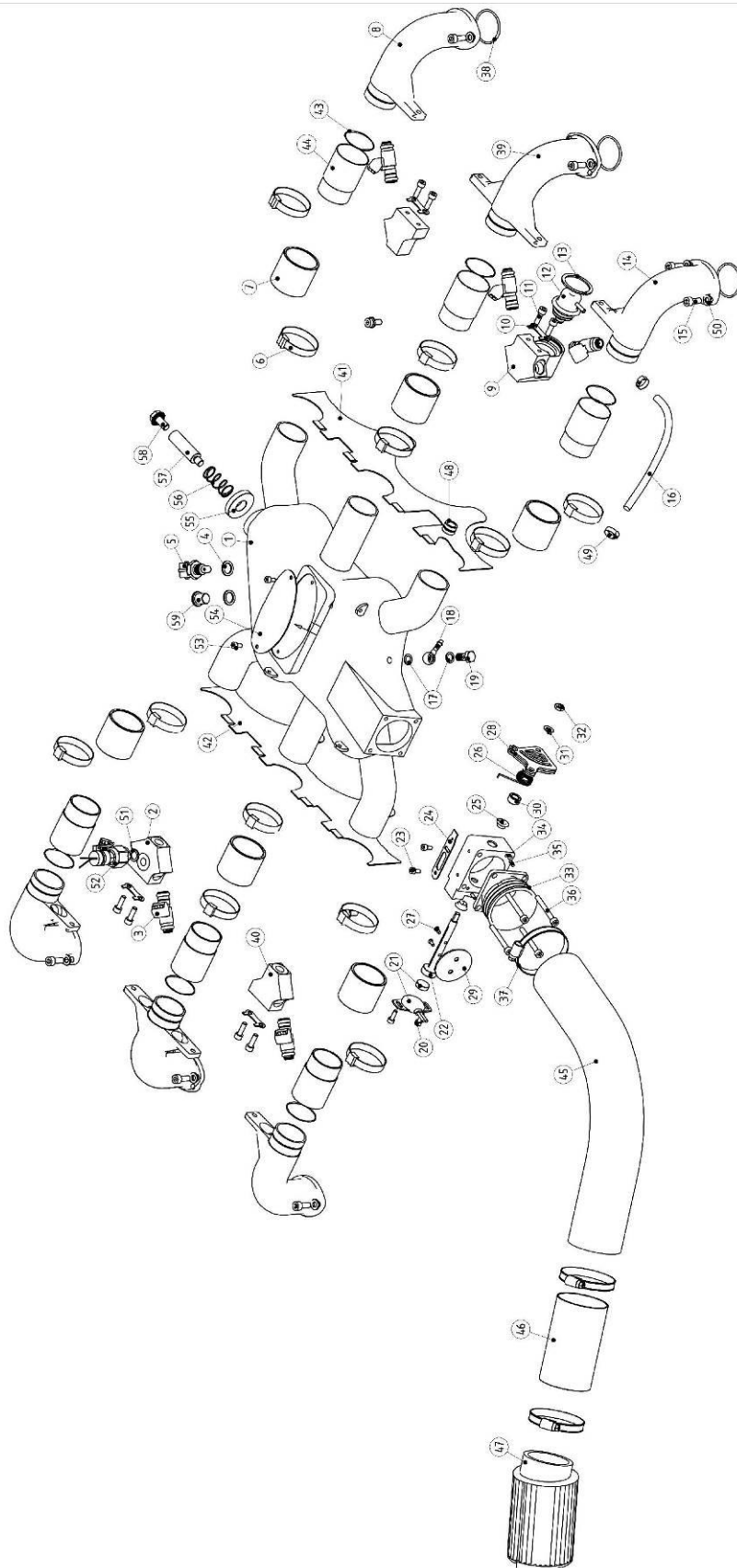

Inlet Manifold, Injectors and Throttle (single ECU)

Item	Part No.	Description	Parts in assembly	Note
1	SE061519	Inlet Collector	1	
2	SE061504 SE061506	Injector +sensor Holder Injector Holder + sensor holder (Forced Cooling)	1 1	
3	E062501	Injector	6	(3)
4	S3121715	Copper Sealing Ring $\varnothing 12 \times 17 \times 1.5$	2	
5	E081515	Air Temperature Sensor	1	20 Nm
6	F2580001	Hose Clamp single use $\varnothing 47$	12	
7	E061511	Rubber Hose 38x3x38	6	
8	E061509	Inlet Tube Right	2	(7)
9	SE061520	Injector + Fuel Pressure Regulator Holder / Bypass	1	
10	SE061512	Injector Holder Lock Plate	4	
11	F1005010	Hex Head Screw - M5x16 - 8.8 Steel - Yellow Passivated	8	6 Nm
12	E064501	Fuel Pressure Regulator - 3bar	1	(3)
13	F1600036	Retaining Ring - bore 36mm	1	
14	E061508	Inlet Tube Left	2	
15	F0106016	Socket Cap Screw - M6x16 - 8.8 Steel - Yellow Passivated	12	10 Nm (2)
16	F2550006	Fuel Pressure Regulator Hose ($\varnothing 4.5 \times 9.5 \times 16 \text{cm}$)	0,3	
17	S3081210	Copper Sealing Ring $\varnothing 8 \times 12 \times 1$	2	
18	F2510708	Banjo Eye M8/ $\varnothing 5$	1	
19	F2520800	Banjo Bolt M8x1	1	6 Nm
20	SUSE060521	Throttle assy 6cyl (contains piece 20-34)		
21	F3604010	Flanged Button Head Socket Cap Screw - M4x10-Zinc Plated	2	
22	E081519	Hall sensor + magnet	1	2 Nm
23	SE060530	Throttle Shaft	1	
24	F0104008	Socket Cap Screw - M4x8 - 8.8 Steel - Yellow Passivated	2	
25	E060506	Throttle Lever Stop	1	3Nm
26	B2200001	Flanged Bushing 8x10x5.5	2	
27	E060511	Throttle Lever Spring	1	
28	F3504008	Button Head Socket Cap Screw - M4x8 - 10.9 Steel - Zinc Plated	2	
29	E060543	Throttle lever outer plate hall sensor	1	
30	E060544	Throttle lever middle plate hall sensor	1	
31	E060545	Throttle lever inner plate hall sensor	1	
32	SE060525	Throttle plate D45	1	
33	E060542	Throttle bushing hall sensor	1	
34	SE061513	Locking plate throttle shaft	1	
35	F5001060	Hex Thin Nut M6-Zn	1	
36	SE060535	Throttle connection	1	
37	SE060521	Throttle housing D45 hall sensor	1	(7)
38	F1803006	Parallel Pin 3x6	2	
39	F0105040	Socket Cap Screw - M5x40 - 8.8 Steel - Yellow Passivated	4	6 Nm
40	F2580007	Hose clamp $\varnothing 40 - 60$	3	
41	S1036020	O - Ring Viton 36 x 2	6	
42	SE061508	Inlet tube middle	2	
43	SE061505	Injector holder single hole	2	
44	SE012510	Baffle right	1	

Item	Part No.	Description	Parts in assembly	Note
42	SE012509	Baffle left	1	
43	S1035012	O - Ring Viton 35 x 1.2	6	
44	BE061515	Inlet extension tube	6	
45	SE060565	Inlet hose D60 - L700	1	
46	SE060560	Inlet tube D60 x 1	1	
47	SE062003	Air filter D60 straight	1	
48	E012517	Protection hose Fp-regulator	1	
49	F2580002	Hose clamp single use Ø10	2	
50	F2110060	Nord lock washer	12	
51	S3101415	Copper sealing ring d10xD14x1.5	1	
52	E081507	Fuel pressure sensor	1	12Nm
53	F0904008	Hex socket button head cap screw M4x8 -10.2 Zn	2	
54	M900016	Logo plaatje	1	
55	SE061515	Overpressure valve	1	
56	F2010006	Spring Ø14,2 x 1,2 L=40	1	
57	SE061514	Overpressure valve body	1	
58	F0808050	hexagon flange bolt M8x50	1	
59	F4621215	Hexagon Socket Screw Plug M12x1,5	1	20Nm

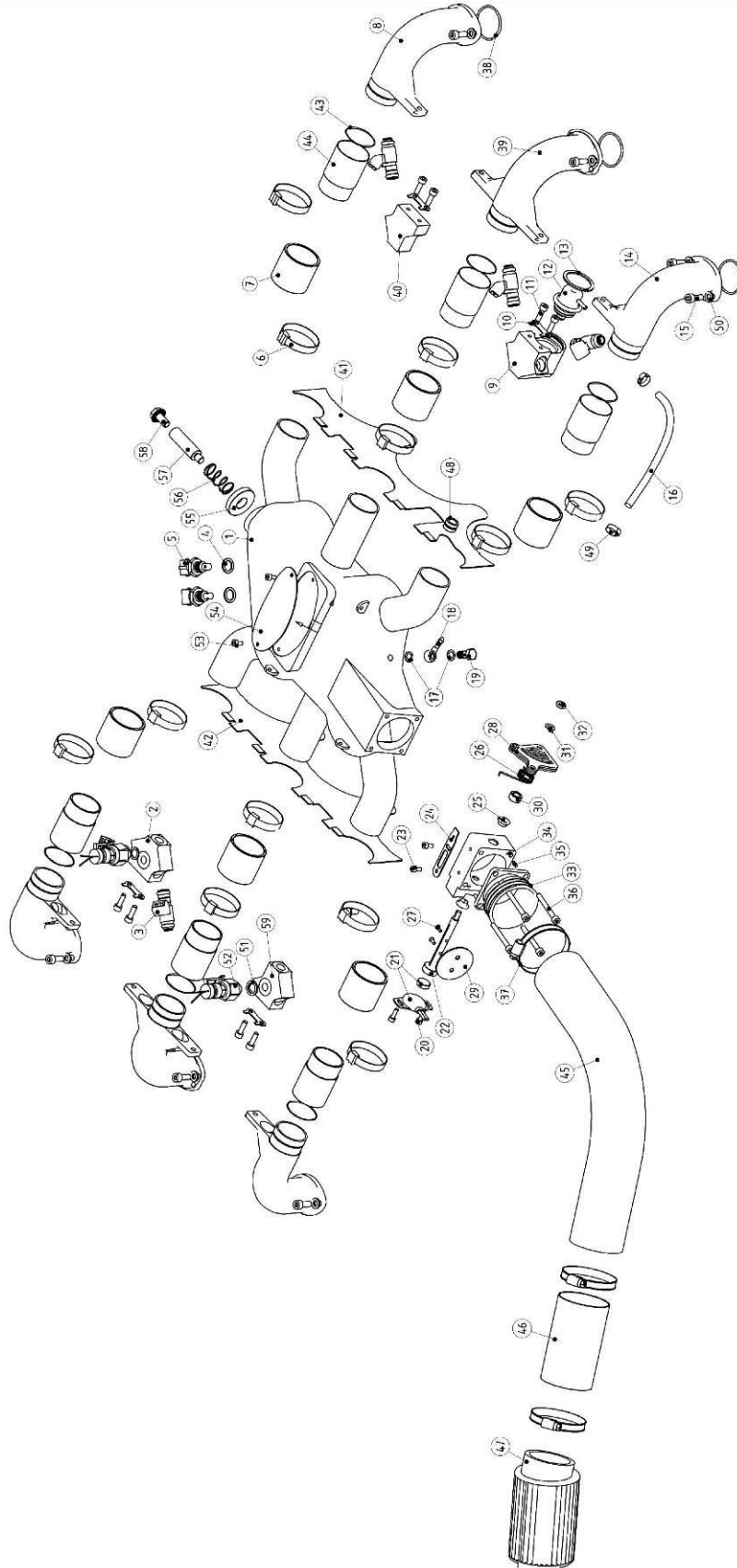

Inlet Manifold, Injectors and Throttle (double ECU)

Item	Part No.	Description	Parts in assembly	Note
1	SE061519	Inlet Collector	1	
2	SE061504	Injector +sensor Holder	1	
	SE061506	Injector Holder + sensor holder (Forced Cooling)	1	
3	E062501	Injector	6	(3)
4	S3121715	Copper Sealing Ring $\varnothing 12 \times 17 \times 1.5$	2	
5	E081515	Air Temperature Sensor	2	20 Nm
6	F2580001	Hose Clamp single use $\varnothing 47$	12	
7	E061511	Rubber Hose 38x3x38	6	
8	E061509	Inlet Tube Right	2	(7)
9	SE061520	Injector + Fuel Pressure Regulator Holder / Bypass	1	
10	SE061512	Injector Holder Lock Plate	4	
11	F1005010	Hex Head Screw - M5x16 - 8.8 Steel - Yellow Passivated	8	6 Nm
12	E064501	Fuel Pressure Regulator - 3bar	1	(3)
13	F1600036	Retaining Ring - bore 36mm	1	
14	E061508	Inlet Tube Left	2	
15	F0106016	Socket Cap Screw - M6x16 - 8.8 Steel - Yellow Passivated	12	10 Nm (2)
16	F2550006	Fuel Pressure Regulator Hose ($\varnothing 4.5 \times 9.5 \times 16 \text{cm}$)	0,3	
17	S3081210	Copper Sealing Ring $\varnothing 8 \times 12 \times 1$	2	
18	F2510708	Banjo Eye M8/ $\varnothing 5$	1	
19	F2520800	Banjo Bolt M8x1	1	6 Nm
20	SUSE060521	Throttle assy 6cyl (contains piece 20-34)		
	F3604010	Flanged Button Head Socket Cap Screw - M4x10-Zinc Plated	2	
21	E081519	Hall sensor + magnet	1	2 Nm
22	SE060530	Throttle Shaft	1	
23	F0104008	Socket Cap Screw - M4x8 - 8.8 Steel - Yellow Passivated	2	
24	E060506	Throttle Lever Stop	1	3Nm
25	B2200001	Flanged Bushing 8x10x5.5	2	
26	E060511	Throttle Lever Spring	1	
27	F3504008	Button Head Socket Cap Screw - M4x8 - 10.9 Steel - Zinc Plated	2	
28	E060543	Throttle lever outer plate hall sensor	1	
	E060544	Throttle lever middle plate hall sensor	1	
	E060545	Throttle lever inner plate hall sensor	1	
29	SE060525	Throttle plate D45	1	
30	E060542	Throttle bushing hall sensor	1	
31	SE061513	Locking plate throttle shaft	1	
32	F5001060	Hex Thin Nut M6-Zn	1	
33	SE060535	Throttle connection	1	
34	SE060521	Throttle housing D45 hall sensor	1	
35	F1803006	Parallel Pin 3x6	2	
36	F0105040	Socket Cap Screw - M5x40 - 8.8 Steel - Yellow Passivated	4	6 Nm
37	F2580007	Hose clamp $\varnothing 40 - 60$	3	
38	S1036020	O - Ring Viton 36 x 2	6	
39	SE061508	Inlet tube middle	2	
40	SE061505	Injector holder single hole	1	
41	SE012510	Baffle right	1	

Item	Part No.	Description	Parts in assembly	Note
42	SE012509	Baffle left	1	
43	S1035012	O - Ring Viton 35 x 1.2	6	
44	BE061515	Inlet extension tube	6	
45	SE060565	Inlet hose D60 - L700	1	
46	SE060560	Inlet tube D60 x 1	1	
47	SE062003	Air filter D60 straight	1	
48	E012517	Protection hose Fp-regulator	1	
49	F2580002	Hose clamp single use Ø10	2	
50	F2110060	Nord lock washer	12	
51	S3101415	Copper sealing ring d10xD14x1.5	2	
52	E081507	Fuel pressure sensor	2	12Nm
53	F0904008	Hex socket button head cap screw M4x8 -10.2 Zn	2	
54	M900016	Logo plaatje	1	
55	SE061515	Overpressure valve	1	
56	F2010006	Spring Ø14,2 x 1,2 L=40	1	
57	SE061514	Overpressure valve body	1	
58	F0808050	hexagon flange bolt M8x50	1	
59	SE061502	Injector (single hole) + sensor holder	1	

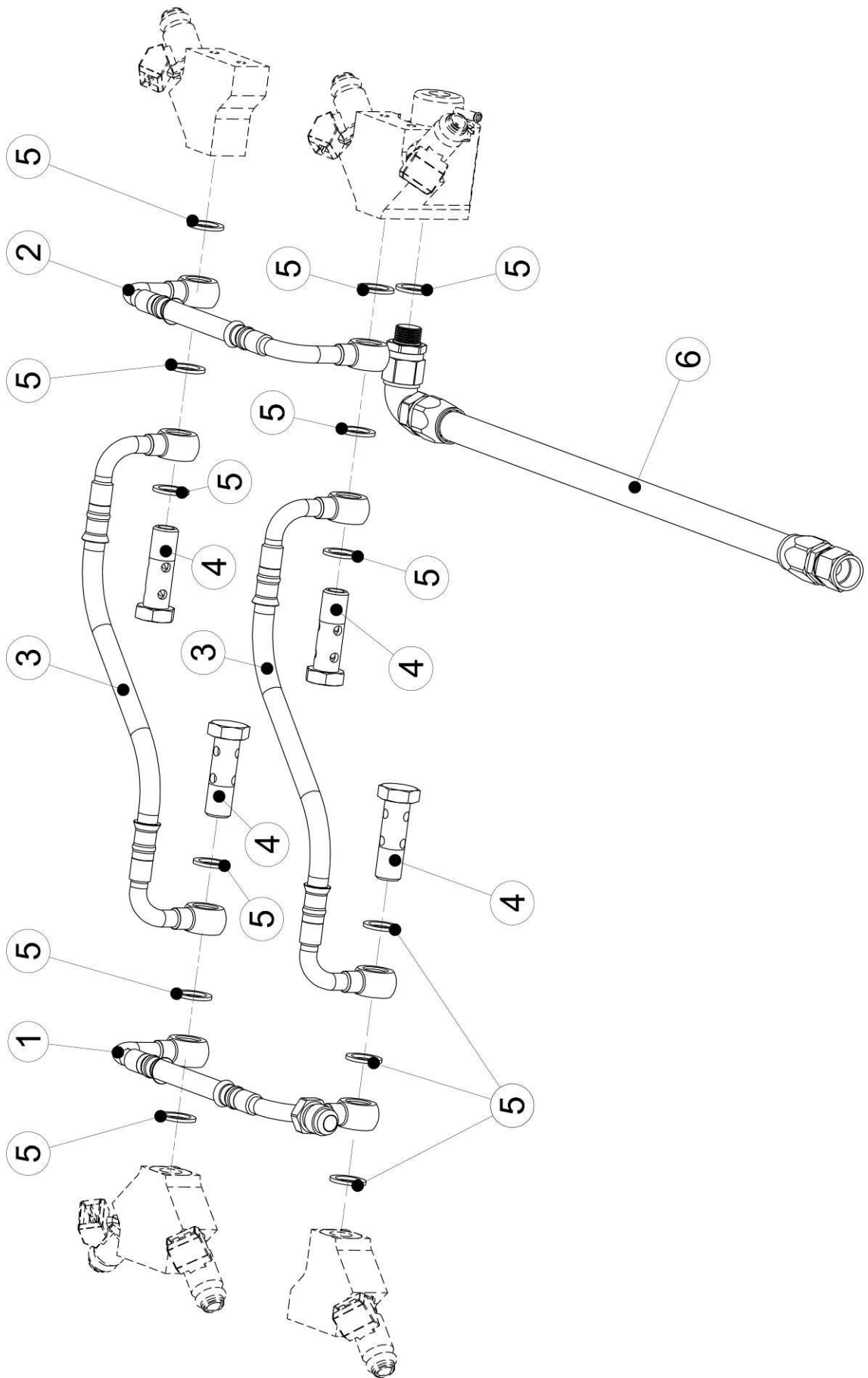

Fuel lines

Item	Part No.	Description	Parts in assembly	Note
1	SE063010	Fuel line connection & feed line	1	
2	SE063011	Fuel line side	1	
3	E063013	Fuel line cross long	2	
4	F2521210	Banjo bolt M12x1.5 double	4	
5	S3121715	Copper sealing ring d12xD17x1.5	13	
6	E063015	Fuel return line 3.5 - 5.2	1	

Assemble 27 & 29

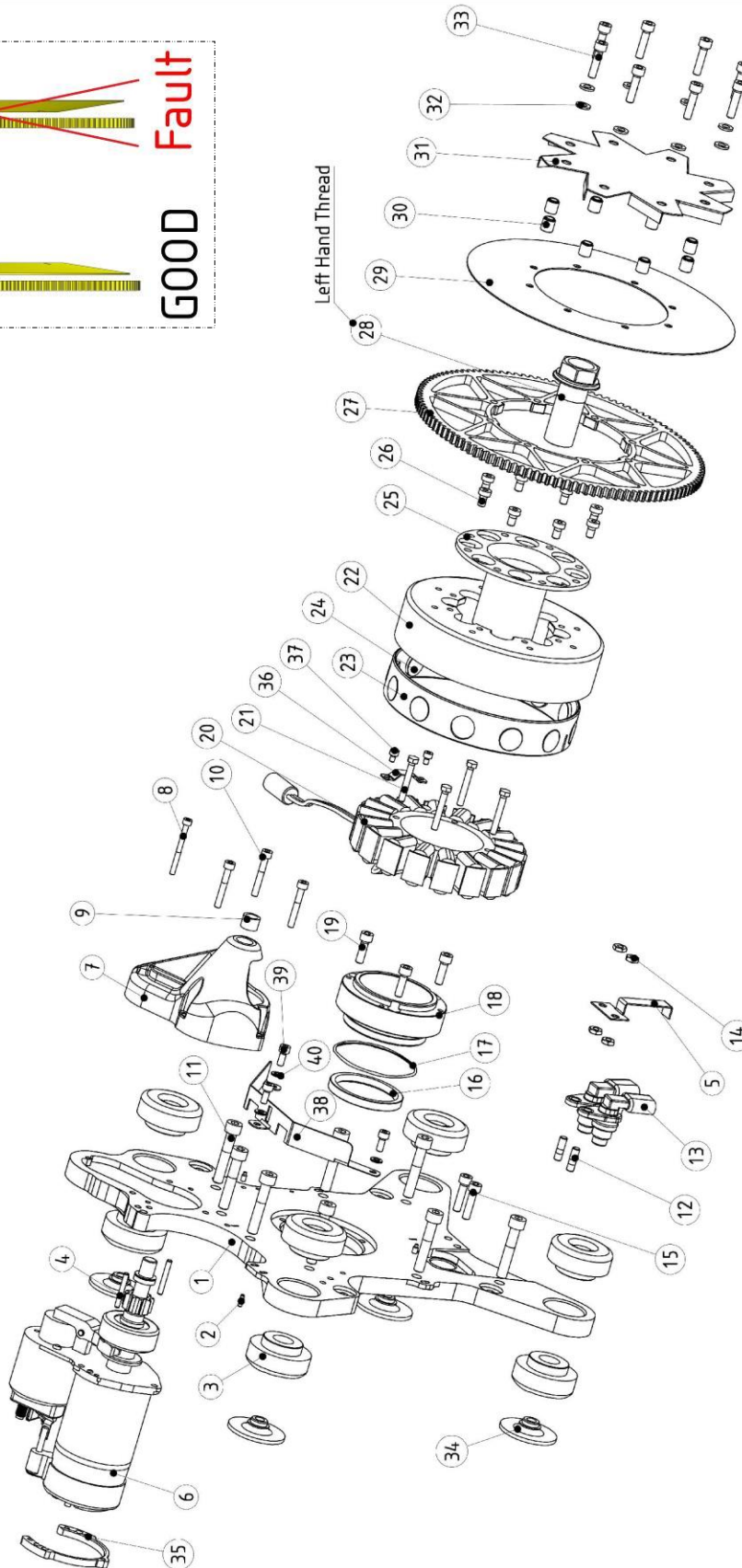
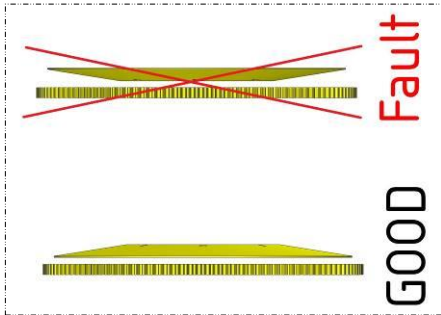

Engine Mount Plate, Starter and Alternator

Item	Part No.	Description	Parts in assembly	Note
1	SE013506 SE013502	Engine Mount Plate Engine Mount Plate double sensor	1	(7)
2	F1803010	Parallel Pin 3x10	2	
3	E014001	Rubber Engine Mount	8	
4	F1804020	Parallel Pin 4x20	2	
5	E072001	Locking plate hall sensor	1	
6	E050501	Starter Engine	1	
7	E050503	Starter Cap	1	
8	F0104035	Socket Cap Screw - M4x35 - 8.8 Steel - Zinc Plated	1	3 Nm
9	B2100001	Bushing 12x14x10	1	
10	F0105030	Socket Cap Screw - M5x30 - 8.8 Steel - Yellow Passivated	3	6 Nm(2)
11	F0108045	Socket Cap Screw - M8x45 - 12.9 Steel - Yellow Passivated	8	25 Nm
12	F4106020	Stud - M6x20 - Yellow Passivated	2	(2)
13	E081503	Hall Sensor	2	(3)
14	F5103060	prevailing torque type hex nut - M6 - Zn	4	6 Nm
15	F0106025	Socket Cap Screw - M6x25 - 8.8 Steel - Yellow Passivated	2	10 Nm
16	S2506207	Oil Seal Viton 50x62x7 GR	1	
17	S1066020	O-Ring Viton ø66x2	1	
18	SE051510	Alternator Stator Spacer	1	(7)
19	F0106020	Socket cap screw M6x20 - 8.8 Steel - Yellow passivated	3	10 Nm(7)
20	SE052001	Alternator Stator	1	
21	F0705040	Hexagon head screw - M5x40 - 8.8 Steel - Zinc plated	4	10 Nm
22	SUSE052000	alternator rotor ass + magnet	1	
23	SE052600	Alternator Flange 6cyl Assembly	1	
24	SE052501	Alternator Magnet Ring	12	
25	SE051502	Alternator Magnet Spacer ring		
26	E052002	Alternator Magnet		
27	SE052508	Alternator rotor flange	1	(8)
28	F0306010	Socket cap screw thin - M6x10 - 12,9 Steel - Zinc plated	8	12 Nm
29	E051001	Starter Ring Gear	1	
30	E023002	Alternator Rotor Flange Bolt / Socket size 30 mm	1	280 Nm (2)
31	E052507	Alternator Fan Assembly (Contains piece 29 , 30 , 31)	1	
32	E052503	Alternator fan base	1	
33	E052504	Spacer alternator fan	8	
34	E052506	Alternator fan top	1	
35	F2110060	NordLock Washer M6	8	
36	F0206028	Socket Cap Screw - M6x28 - 8.8 Steel - Zn	8	10 Nm
37	E013505	Engine Mount Washer	4	

Item	Part No.	Description	Parts in assembly	Note
35	E050504	Starter Fixing Ring	1	
36	E013030	Bracket Alternator Guide	1	
37	F0104006	Socket Cap Screw M4x6 8-8 yellow	2	
38	E013031	Alternator Protection plate	1	
39	F0105012	Socket cap screw M5x12 - 8.8 Steel yellow passivated	3	
40	F2110050	Nordlock Washer M5	3	

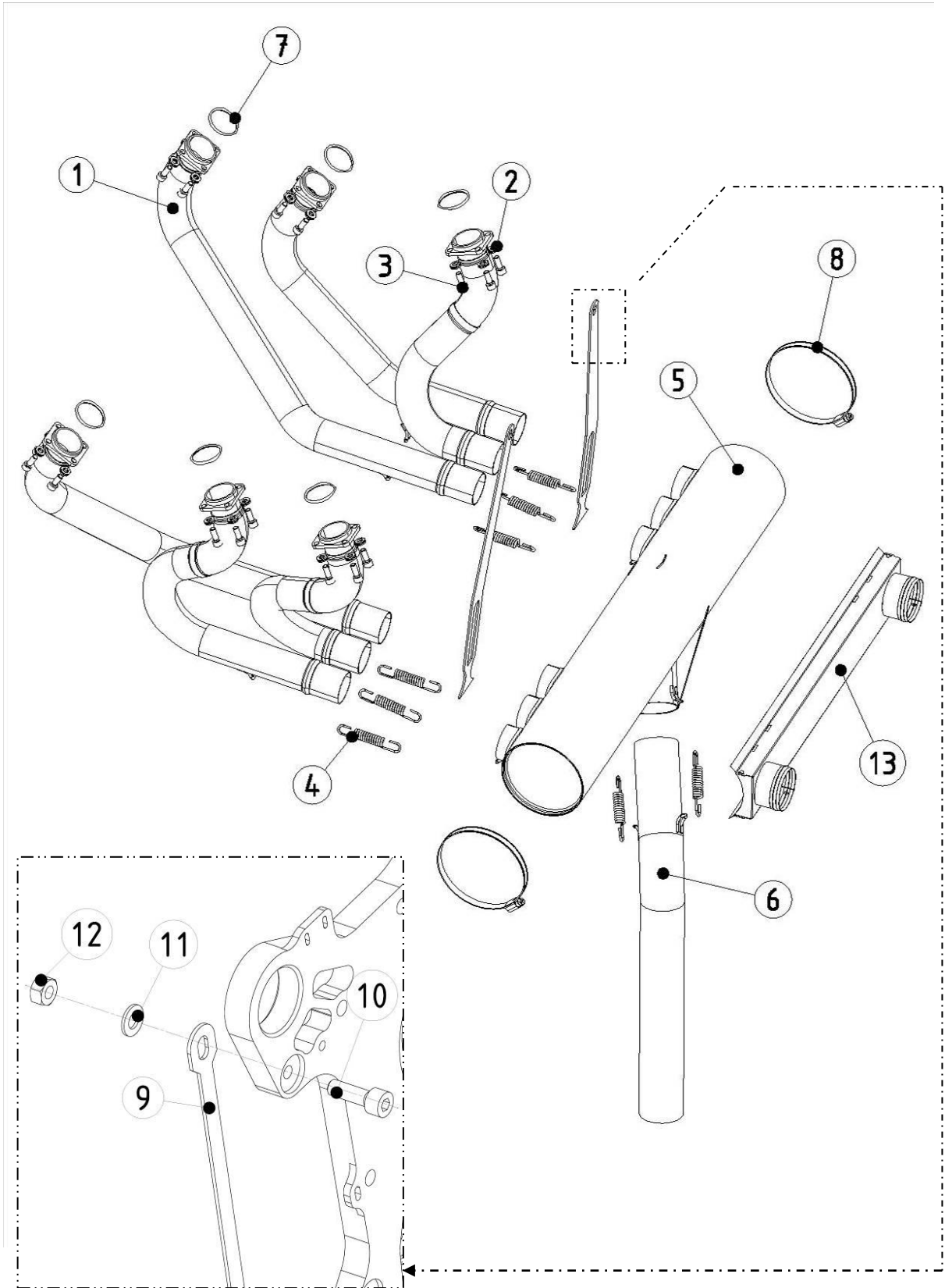

Exhaust System

Item	Part No.	Description	Parts in assembly	Note
1	SBE091110	Stainless Steel Exhaust Tubes (set)	1	
2	F2110060	NordLock Washer M6	24	
3	F0106016	Socket Cap Screw - M6x16 - 8.8 Steel - Yellow Passivated	24	10 Nm (1)
4	E093001	Exhaust Spring	8	
5	SBE091516	Stainless Steel Muffler L=600	1	
6	SE093505	Exhaust Tube	1	
7	E092002	Exhaust gasket ring Inox d32xD38x2.5	6	
8	F2580008	Hose clamp ø 90 - 110 / Stainless steel	2	
9	BE093005	Muffler bracket 3.5 - 5.2	2	
10	F0108025	Cap Screw M8x25 -8,8 Yellow	2	20 Nm
11	F2710008	Flat washer M8	2	
12	F5103080	Prevailing Hexagon nut all metal M8	2	
13	E092509	Muffler heating box (Optional)	1	

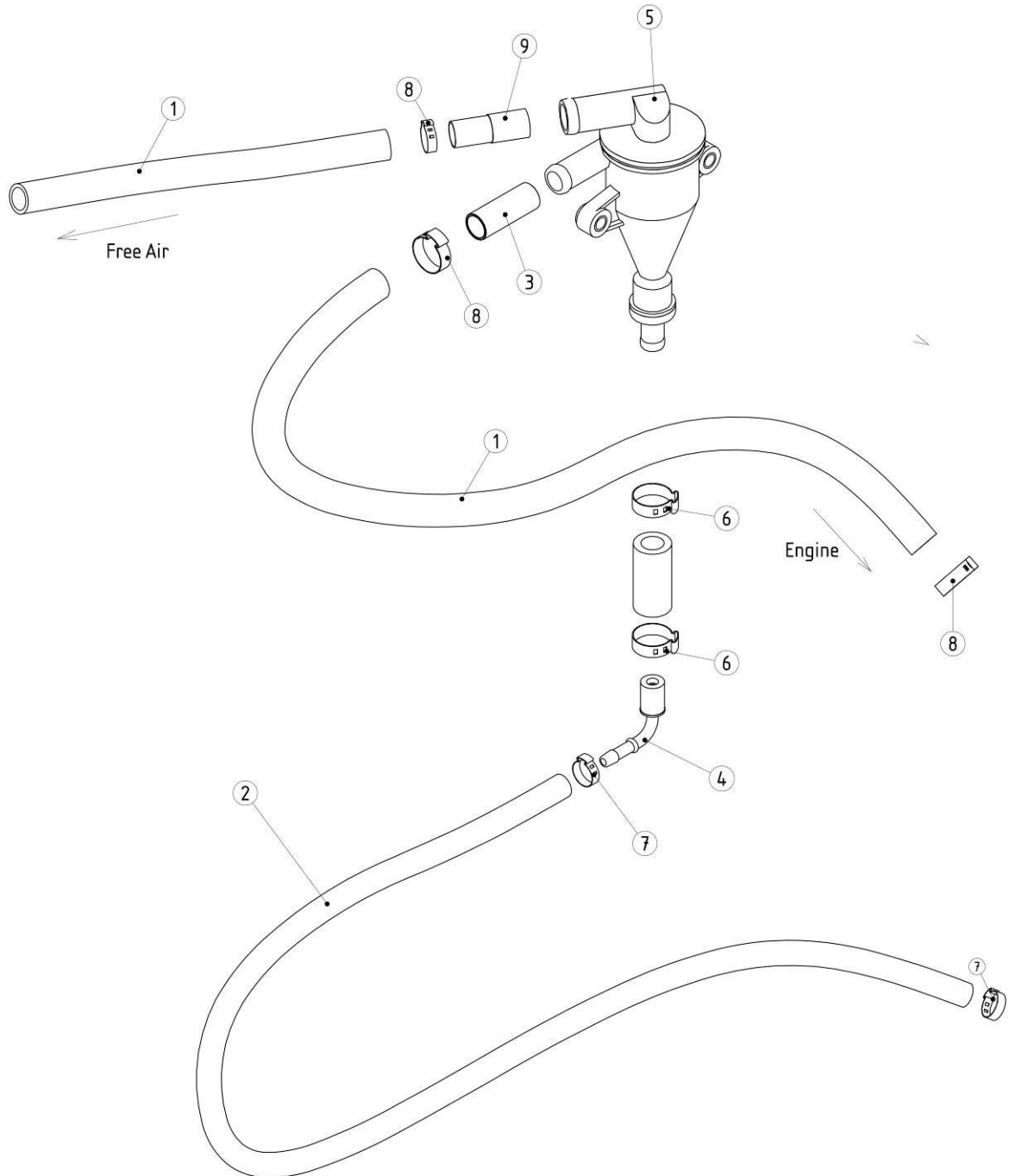

Breather and Oil/Air Separator

Item	Part No.	Description	Parts in assembly	Note
1	F2550010	Cloth Braided Hose $\varnothing 15 \times 20$	2	
2	F2550007	Rubber Hose $\varnothing 6 \times 13.5$ (125 °C)	1	
3	SE043500	Oil/Air separator assembly (Contains piece 3,4,5,6,7,8,9)		
	SE044006	Tube $\varnothing 15 \times \varnothing 12.5 \times 40$	1	
4	E044003	Elbow connection oil return (assembly)	1	
5	E043506	Oil/Air separator (30°)	1	
6	F2580004	Hose clamp $\varnothing 20$	2	
7	F2580003	Hose clamp $\varnothing 14.5$	2	
8	F2580010	Hose clamp $\varnothing 21$	3	
9	E043509	Reduction Oil/Air Separator	1	

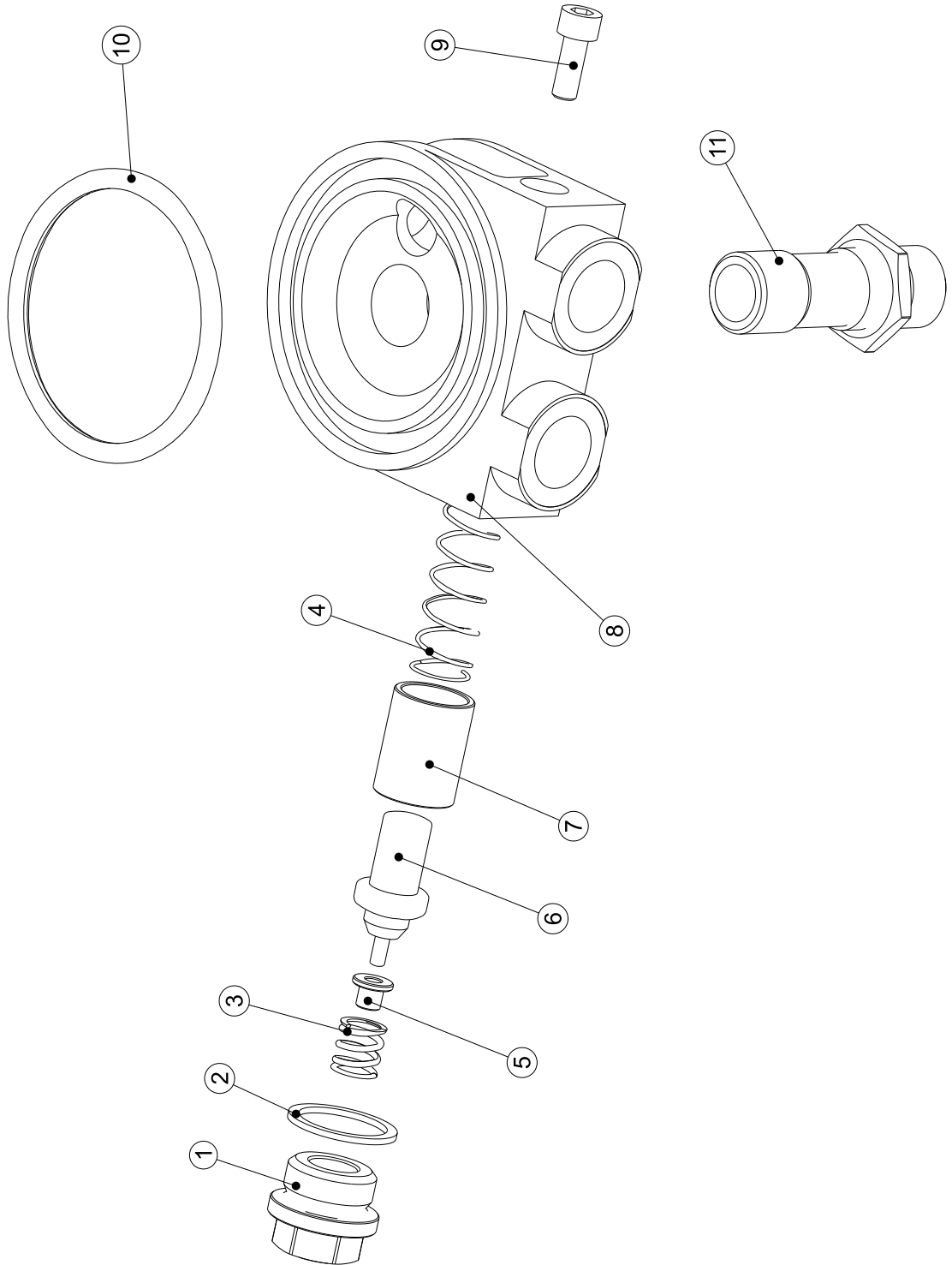

Oil Thermostat : E042515

Item	Part No.	Description	Parts in assembly	Note
1	E42520	Plug M22x1,5	1	20Nm
2	S3222715	Copper sealing 22x27x1,5	1	(4)
3	F2010010	Spring VDSiCr Ø1,60x8,00x14.50 mm	1	
4	F2010020	Spring VDSiCr Ø1,4x14,00x46,50 mm	1	
5	E042540	Spring Holder	1	
6	E042501	Bi metal	1	
7	E042530	Bimetal Cover	1	
8	SE042510	Thermostat housing	1	
9	F0206025	Socket Cap Screw - M6x25 - 8.8 Steel	1	10 Nm
10	S1062050	O-Ring Viton Ø 62x5	1	
11	E042007	Oil filter adapter screw M20 x 1.5	1	20 Nm

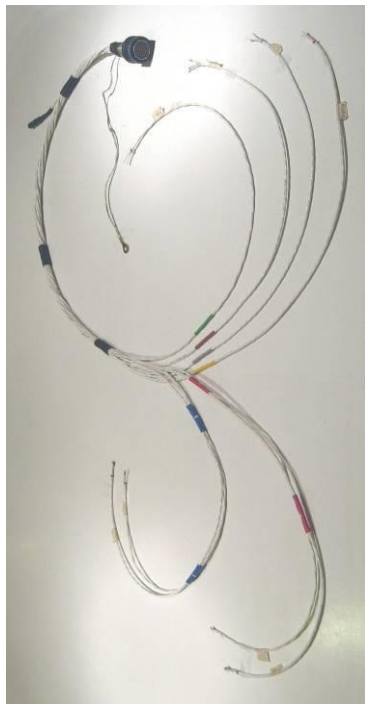

8



7

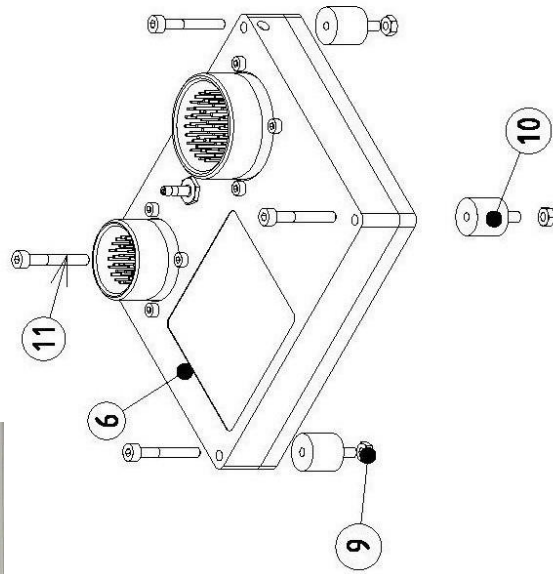

6

9

10

11

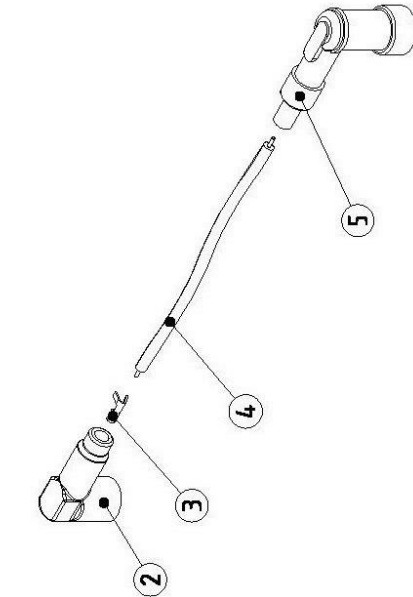

2

3

4

5

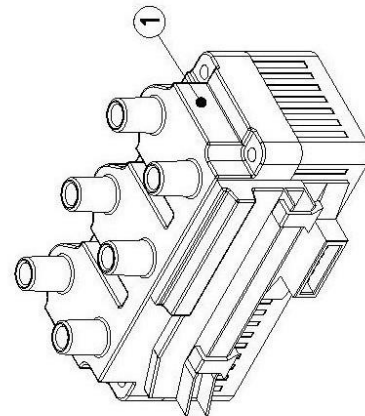

1

Ignition and Engine Control Unit

Item	Part No.	Description	Parts in assembly	Note
1	SE071005	Ignition Coil	1	
2	E071501	Ignition Coil Cover	1	
3	E071505	Copper Clamp (for Ignition Coil Cover)	1	
4	E071503	Ignition Lead Cable	1	
5	E071504	Spark Plug Cover	1	
6	SBE080510	Engine Control Unit UL 520i	1	
	SBE080511	Engine Control Unit UL 520iS	1	
7	SE081006 SE081008	ECU Wiring loom engine L = 1100 (Single ECU) ECU Wiring loom engine L = 1100 (Double ECU)	1	
8	SE081007 SE081012 SE081013	ECU Wiring loom cockpit (4 + 6 cylinder) L = 1000 (Single ECU) ECU Wiring loom cockpit double (4 + 6 cylinder) L = 1000 ECU A ECU Wiring loom cockpit double (4 + 6 cylinder) L = 1000 ECU B	1	
9	F5102040	Prevailing hexagon nut M4	4	4 Nm
10	F2641515	Silent bloc M4 type B - hoogte 15	4	
11	F0204030	cap screw M4x30-8,8 yellow	4	4 Nm

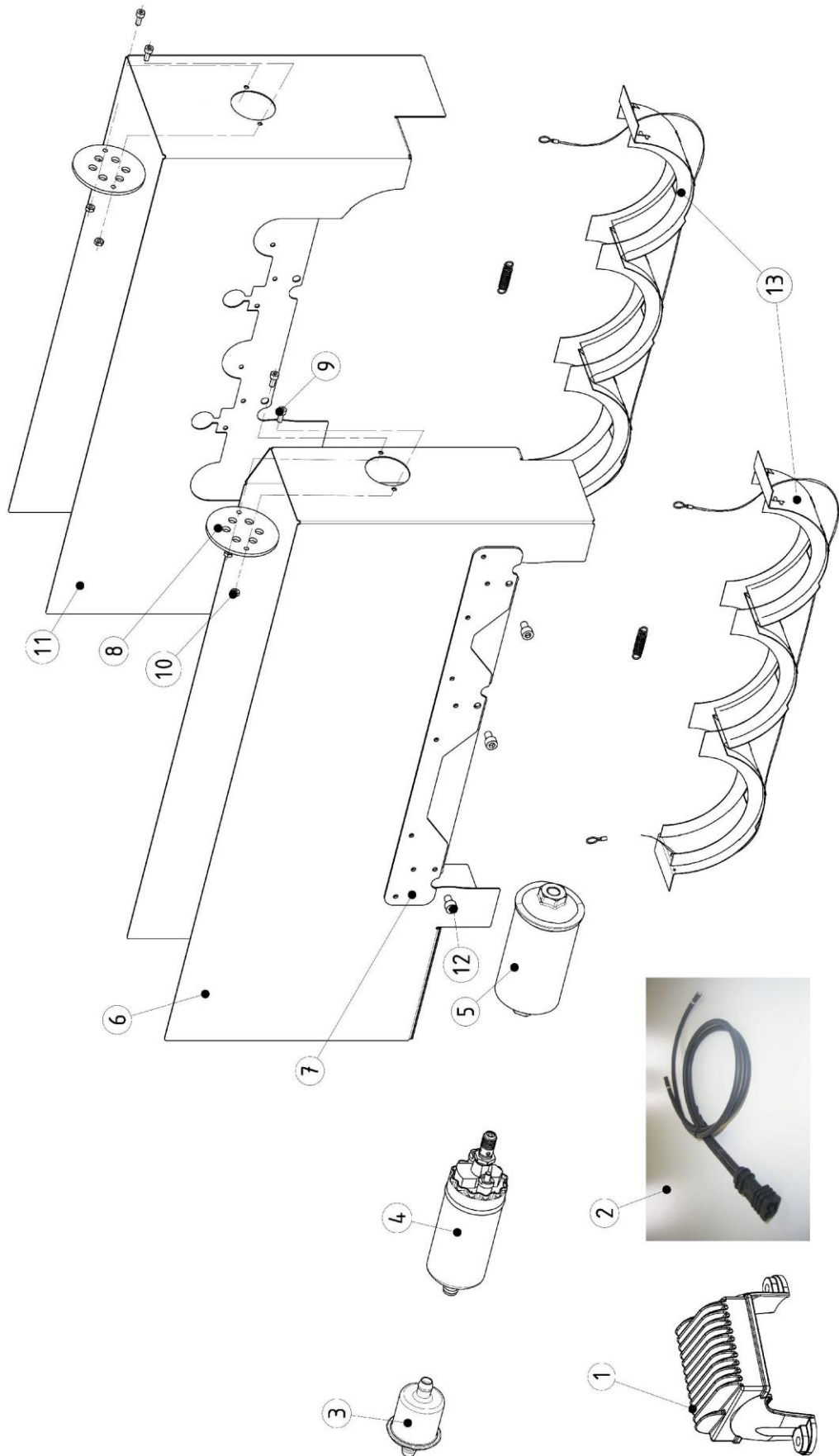

Accessories

Item	Part No.	Description	Parts in assembly	Note
1	SE053003	Regulator 50A	1	
2	SE053010	Cable regulator - battery	1	
3	E064003	Fuel Filter (Pre-filter)	1	
4	E063502	Fuel Pump	1	
5	E064001	Fuel Filter (Fine)	1	
6	SE012507	Assembly Cylinder Head Ram Air Box (Left)	1	
7	SE012524	Cylinder Head Ram Air Box (Left)	1	
8	SE011504	Reinforcing Rib	1	
9	F0204010	Ignition Cable Grommet	1	
10	F0204010	Cap screw M4x10 - 8.8 Zn	4	
10	F5102040	Prevailing Hexagon nut M4	4	4 Nm
11	SE012508	Assembly Cylinder Head Ram Air Box (Right)	1	
7	SE012524	Cylinder Head Ram Air Box (Right)	1	
8	SE011504	Reinforcing Rib	1	
9	F0204010	Ignition Cable Grommet	1	
10	F0204010	Cap screw M4x10 - 8.8 Zn	4	
10	F5102040	Prevailing Hexagon nut M4	4	4 Nm
12	F0106016	Cap Screw M6x16-8-8 Yellow	6	10 Nm
13	SE013002	Cylinder baffle	2	
		Spring 1.0x8x35	2	
		Steel Cable	1	

Section of drawings

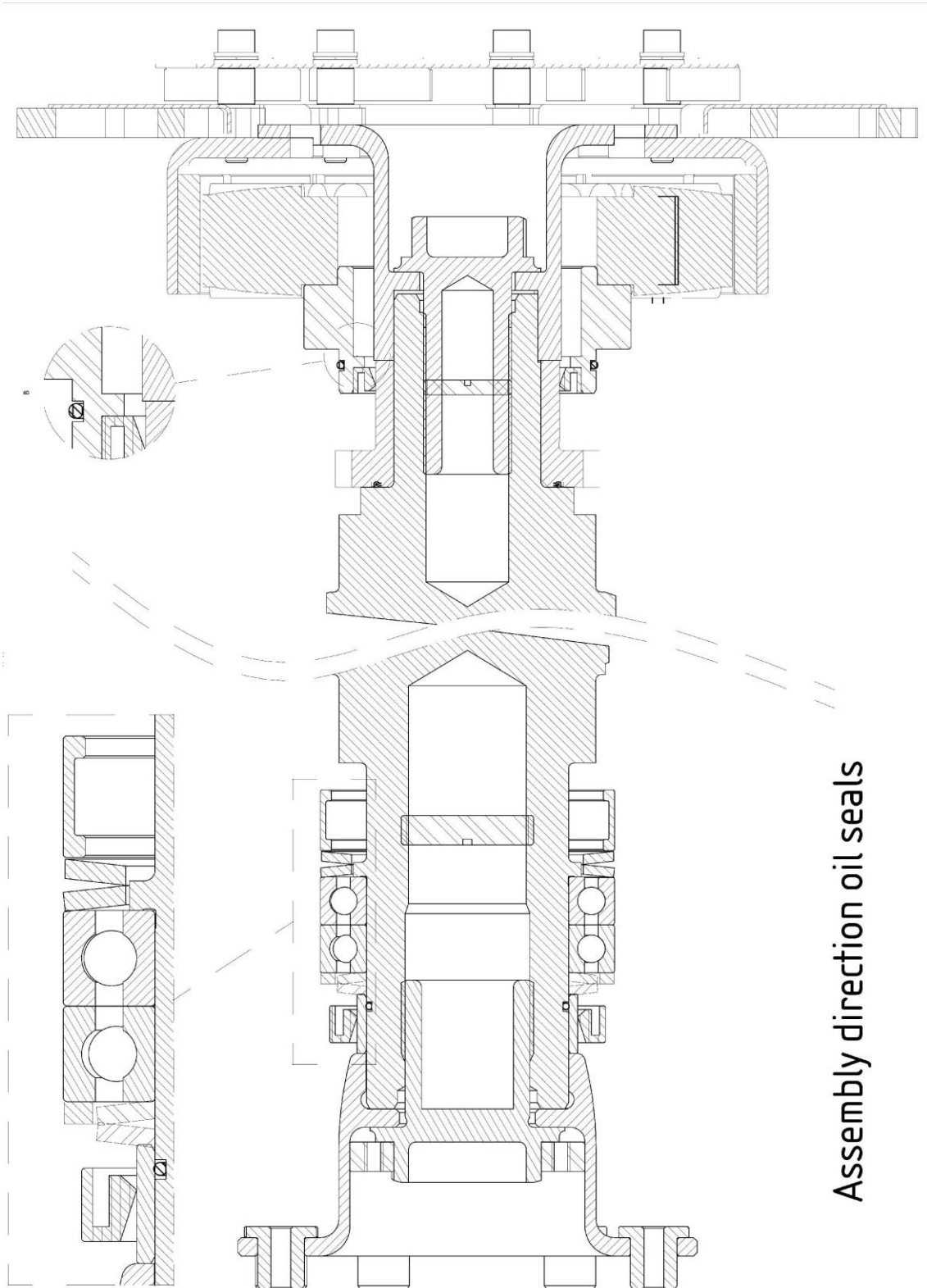

Assembly direction oil seals

Notes

- (1) Loctite 8009 (High Temperature Resistant Grease)
- (2) Loctite 266 (Thread Locker)
- (3) Engine Oil
- (4) Replace When Removed
- (5) Loctite 5910 (Quick Gasket)
- (6) Loctite 577 (Thread Sealant)
- (7) Elring No. 030.792 (Sealing Silicone)
- (8) Loctite 573 (Flange Sealant)
- (9) Loctite 542 (Thread Sealant)

Revision

Revision 5 (2015-12-15)

Inlet Manifold, injectors ad throttle => "Single" AND "Double" ECU

Item 6: Hose clamp Ø44 => Hose clamp Ø47
Item 35: Hose clamp Ø62 => Hose clamp Ø63,5

Engine Mount Plate, starter and alternator

Item 32: Engine Mount Washer

Exhaust system

New clamping of the Muffler bracket

Breather and oil/air separator

Item 7: Reduction Oil/air separator

Oil thermostat

Item 2: copper sealing 22x28x1,5 => 22x27x1,5
Item 10: S1052025 => S1062050

Ignition and engine control unit

Item 10: Silent bloc
Item 11: Cap screw M4
Item 12: Prevailing hexagon nut M4

Accessoires

Item 7, 14: Air box Left/right => Reinforcing rib + clips + Ignition cable grommet
Item 13: Cap Screw M4x16-8-8 Yellow

Revision 6: (15/09/2016)

Pg 4 and pg 5: Cylinder head and cylinder => nr 21 (Nordlock washer M5)

Pg 14 and pg 15: Inlet manifold, injectors and throttle => nr 49 (Nordlock washer M6)

Just used the partnumber. (no version)

Pg 28/29: Nr 16: E013025 (Steel Cable)

Revision 7: (19/10/2017)

Pg 28/29: Nr 16: E013025 (Steel Cable)

Revision 8: (01/06/2018)

Pg 4 - 5: Nr. 22

Pg 6 - 7: Nr11: E081507 (Oil Pressure Sensor) / E081516 was E081501 / Nr 40 and 41

Pg 9: Nr18: S1016020 was S1013020

Pg 9: nr 16: E041040 was F4621615

Pg 12 -13: Nr 21

Pg 14 - 16: Nr1: SE061519 was SE061510, Nr2: SE061504 was SE061503, + extra 50 - 57

Pg 18: Detail Montage E052503

Pg 19: Nr 27: E052503 was E052505

Pg 25: Nr 7: 1=>2st

Pg 27: SE081002 => SE081006 / SE081003 => SE081007 / SE081004 => SE081008 / SE081005 => SE081009

Pg 28 -29: Nr 8: Clips deleted

Silicone 030.792 was 030.790

Revision 9 (2019-10-01)

Pg 12 en 13: Nr 24 F1305016 was F1306016

Pg 14 en 15: Nr 9: SE061520 was SE061507

Pg 20 en 21: Nr 8 F0104035 was F0104045 en Nr10 F0105030 was F0105035

Revision 10 (2020-02-10)

Pg 6 en 7: Nr 27- Nr 30 verwijderd (Nylon Cable Tie)

Nr 38 - Nr 40 toegevoegd.

Nr 27: S3142015 was S3141815

Nr37: Single ECU / Double ECU

Pg 12 en 13: Nr 24: O-ring Viton

Pg 14 en 15: Throttle assy SUSE060521 was SUE060520 / E081819 was E081506 / SE060521 was SE060520

Pg 19 - 21: Double ECU

Pg 24 en 25: Nr 33: E050504 (Starter fixing ring) / (2) bij nr 10

Nr34 -35: Bracket ALternator Guide)

Pg 30 en 31: Nr 3: F2010010 was F2010002

Nr 4: F2010020 was F2010002

Pg 34 en 35: Nr 13 Spring 1.0x8x35 (F2010003) en Steel Cable (E013025) zit in assembly SE013002

Pg 36: Section of drawing

Revision 11 (2020-07-01)

Pg 12 en 13: Nr 17: E024009 was E024001 / E024008 was E024005

Pg 28 en 29: Nr 9 (E043509) toegevoegd + nr 1 en 8

Revision 12 (2021-06-01)

Pg 08 - 09 : Nr 19 S1006015 toegevoegd

Pg 12 - 13 : Nr 19 Detail

Pg 14 - 20: Nr 57: F0808050 was F08080060
Pg 24 -25 : Nr 14 (F5103060) 8Nm was 10Nm
Pg 32 - 33: Nr 8: SE081009 is vervangen door SE081012 en SE081013
Pg 37 : Detail bij Section of drawings

Revision 13 (2022 - 04 -01)

Pg 06 en 07: Nr 25 SE041001 was E041002
Nr 27: QTY 2 was 1
Nr 41: E041010 Toegevoegd

Pg 12 en 13: Nr 21 was E020510
Nr 21 F1306012 was F1305016
Nr 25: S1028020 (O-ring viton 28x2) toegevoegd
Oil Stop Crankshaft front & O-ring Viton Ø28x2 verwijderd
Oil Stop M24x1,5 verwijderd

Revision 14 (2023 - 06 -01)

Pg 04 en 05: Nr 18 verwijderd (S1105020: O-ring Viton)

Pg 04 en 05: Nr 22: S3101415 (copper ring) toegevoegd

Pg 06 en 07: Nr 6 SE041045 was F4621615

Pg 6-7: Nr 14 S1012020 (O-Ring Viton ø12x2) was S1011020 (O-Ring Viton ø11x2)

Pg 24 en 25: Nr 22: SE052600 was SE052505 (23 - 24 toegevoegd)

Pg 39: Notes toegevoegd

Revision 15 (2024 - 02 -01)

Pg 14- 16: nr 43: S1035012 was S103510 (O-ring 35x1 word O-ring 35x1.2)

Pg 18- 20: nr 43: S1035012 was S103510 (O-ring 35x1 word O-ring 35x1.2)

Pg 24-26: Nr 14: 6Nm was 8Nm
Nr 38 - 40 toegevoegd (Alternator Protection Plate)

Pg 28-29: Nr 13: E092509 was E092502

Revision 16 (2025-04-30)

Pg 28-29: Nr 7: E092002 was E092001 (Exhaust gasket ring Inox d32xD38x2.5)